

## Features

- 100Watts peak pulse power ( $t_p = 8/20\mu s$ )
- Bidirectional configurations
- Solid-state silicon-avalanche technology
- Low clamping voltage
- Low leakage current

## IEC COMPATIBILITY (EN61000-4)

- IEC 61000-4-2  $\pm 25kV$  contact  $\pm 25kV$  air
- IEC 61000-4-4 (EFT) 40A (5/50ns)
- IEC 61000-4-5 (Lightning) 10A (8/20 $\mu s$ )

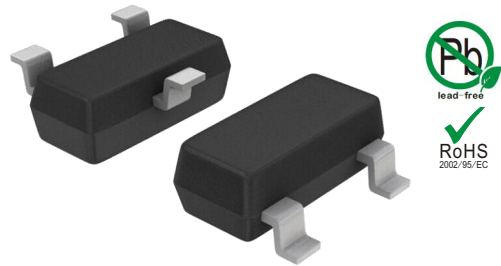

**SOT523**

## Applications

- Microprocessor based equipment
- Personal Digital Assistants (PDA's)
- Notebooks, Desktops, and Servers
- Portable Instrumentation
- Pagers Peripherals

## Mechanical Characteristics

- SOT-523 package
- Molding compound flammability rating: UL 94V-0
- Packaging: Tape and Reel
- RoHS/WEEE Compliant

## Schematic & PIN Configuration

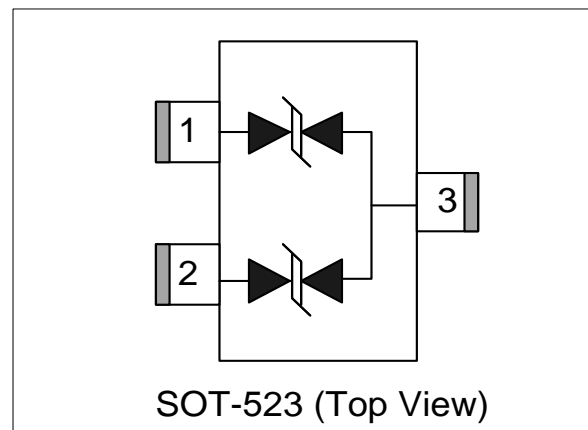
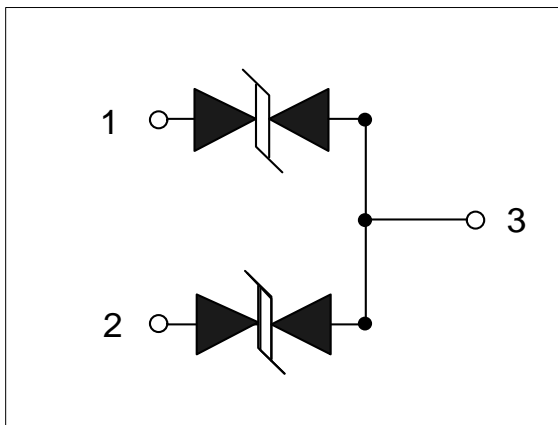

### Absolute Maximum Rating

Rating	Symbol	Value	Units
Peak Pulse Power ( $t_p = 8/20\mu s$ )	$P_{PP}$	100	Watts
Peak Pulse Current ( $t_p = 8/20\mu s$ ) (note1)	$I_{pp}$	10	A
ESD per IEC 61000-4-2 (Air) ESD per IEC 61000-4-2 (Contact)	$V_{ESD}$	25 25	kV
Lead Soldering Temperature	$T_L$	260(10seconds)	°C
Junction Temperature	$T_J$	-55 to + 150	°C
Storage Temperature	$T_{stg}$	-55 to + 150	°C

### Electrical Characteristics

Parameter	Symbol	Conditions	Min	Typical	Max	Units
Reverse Stand-Off Voltage	$V_{RWM}$				5.0	V
Reverse Breakdown Voltage	$V_{BR}$	$I_T = 1mA$	6.0			V
Reverse Leakage Current	$I_R$	$V_{RWM} = 5.0V, T = 25^\circ C$			1	$\mu A$
Clamping Voltage	$V_C$	$I_{PP} = 10A, t_p = 8/20\mu s$			10	V
Junction Capacitance	$C_j$	$V_R = 0V, f = 1MHz$		10	15	pF

### Electrical Parameters (TA = 25°C unless otherwise noted)

Symbol	Parameter
$I_{PP}$	Maximum Reverse Peak Pulse Current
$V_C$	Clamping Voltage @ $I_{PP}$
$V_{RWM}$	Working Peak Reverse Voltage
$I_R$	Maximum Reverse Leakage Current @ $V_{RWM}$
$V_{BR}$	Breakdown Voltage @ $I_T$
$I_T$	Test Current

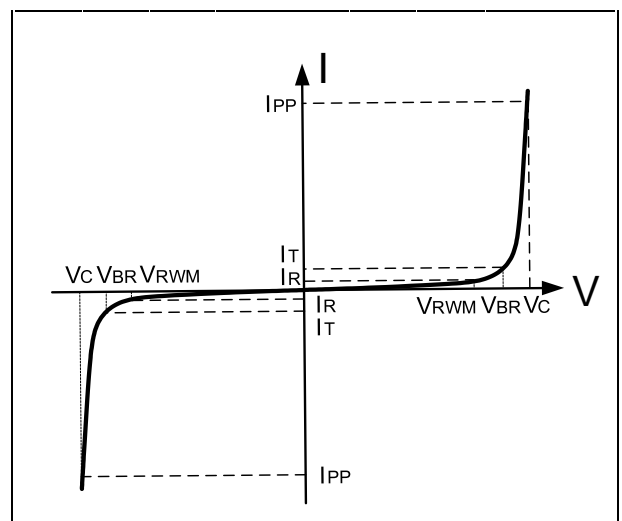

Note: 8/20 $\mu s$  pulse waveform.

## Typical Characteristics

**Figure 1: Peak Pulse Power vs. Pulse Time**

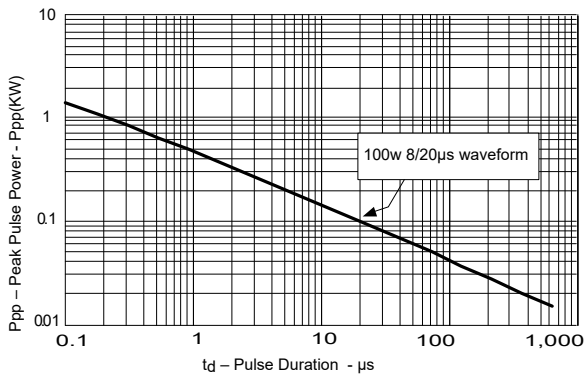

**Figure 2: Power Derating Curve**

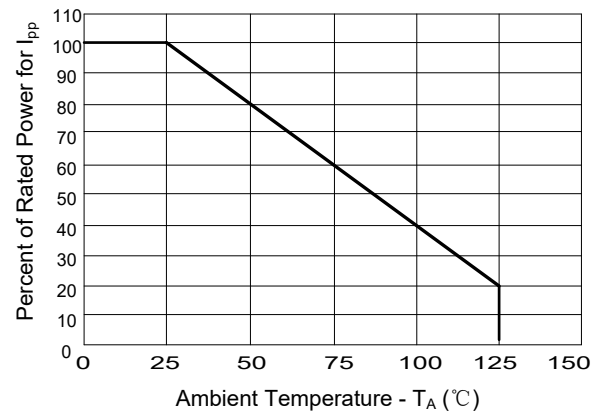

**Figure3: Pulse Waveform**

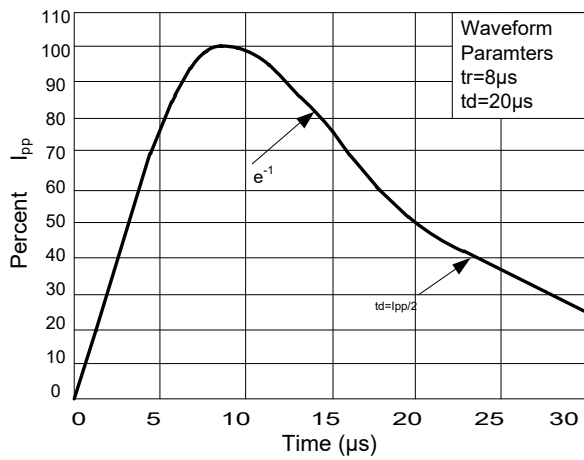

**Figure 4: Clamping Voltage vs. Ipp**

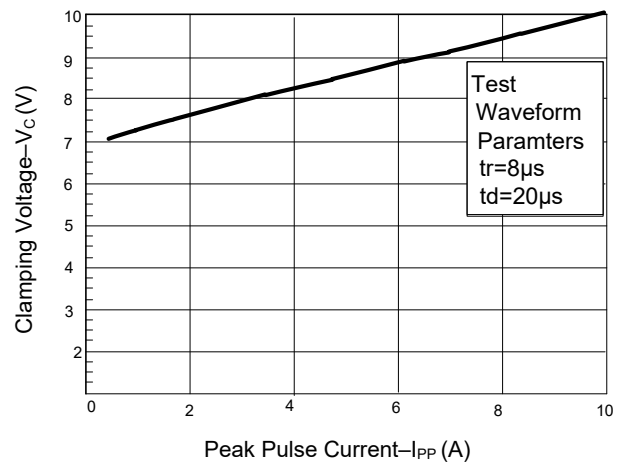

## Outline Drawing

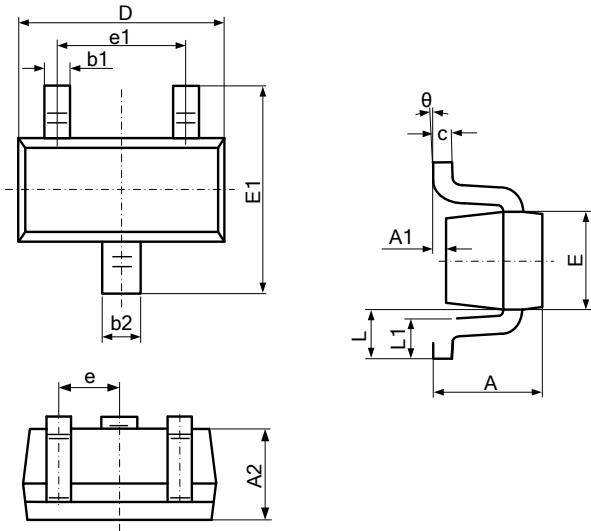

Dimensions				
Symbol	Millimeter		Inches	
	MIN	MAX	MIN	MAX
A	0.700	0.900	0.028	0.035
A1	0.000	0.100	0.000	0.004
A2	0.700	0.800	0.028	0.031
b1	0.150	0.250	0.006	0.010
b2	0.250	0.325	0.010	0.013
c	0.100	0.200	0.004	0.008
D	1.500	1.700	0.059	0.067
E	0.750	0.850	0.030	0.033
E1	1.450	1.750	0.057	0.069
e	0.950 BSC		0.037 BSC	
e1	0.900	1.100	0.035	0.043
L	0.300	0.500	0.012	0.020
L1	0.028	0.440	0.011	0.017
θ	0	8°	0	8°

## Marking

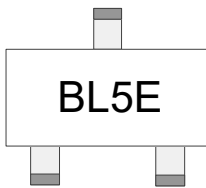

## Ordering information

Order code	Package	Base qty	Delivery mode
PTT523L10M5BA10	SOT-523	3K	Tape and reel