

## Features

- 60Watts peak pulse power ( $t_p = 8/20\mu s$ )
- Solid-state silicon-avalanche technology
- Low clamping voltage
- Low leakage current
- Low capacitance ( $C_j = 0.3pF$  typ. IO to IO)

## IEC COMPATIBILITY (EN61000-4)

- IEC 61000-4-2  $\pm 25kV$  contact  $\pm 25kV$  air
- IEC 61000-4-4 (EFT) 40A (5/50ns)
- IEC 61000-4-5 (Lightning) 4.0A (8/20 $\mu s$ )

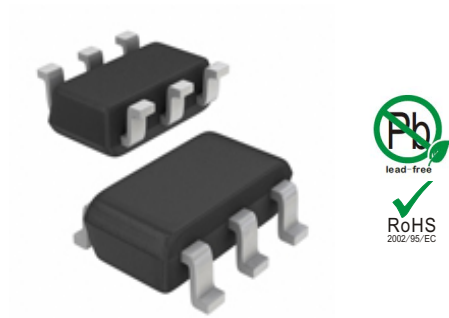

**SOT23-6**

## Applications

- Ethernet
- Digital Visual Interface (DVI)
- USB2.0
- Notebook and PC Computers

## Mechanical Characteristics

- SOT23-6 package
- Molding compound flammability rating:  
UL 94V-0
- Packaging: Tape and Reel
- RoHS/WEEE Compliant

## Schematic & PIN Configuration

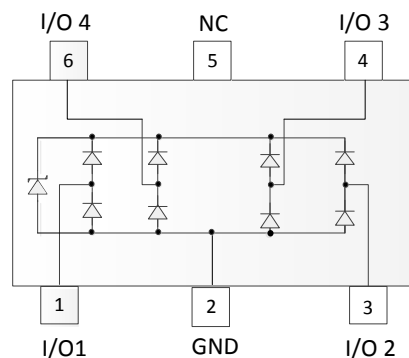

**SOT23-6**

### Absolute Maximum Rating

Rating	Symbol	Value	Units
Peak Pulse Power ( $t_p = 8/20\mu s$ )	$P_{PP}$	60	Watts
Peak Pulse Current ( $t_p = 8/20\mu s$ ) (note 1)	$I_{pp}$	4.0	A
ESD per IEC 61000-4-2 (Air) ESD per IEC 61000-4-2 (Contact)	$V_{ESD}$	25 25	kV
Lead Soldering Temperature	$T_L$	260(10seconds)	°C
Junction Temperature	$T_J$	-55 to + 125	°C
Storage Temperature	$T_{stg}$	-55 to + 125	°C

### Electrical Characteristics

Parameter	Symbol	Conditions	Min	Typical	Max	Units
Reverse Stand-Off Voltage	$V_{RWM}$				5.0	V
Reverse Breakdown Voltage	$V_{BR}$	$I_T = 1mA$	6	8.0		V
Reverse Leakage Current	$I_R$	$V_{RWM} = 5V, T = 25^\circ C$		0.2	0.5	$\mu A$
Peak Pulse Current	$I_{PP}$	$t_p = 8/20\mu s$			4.0	A
Clamping Voltage	$V_C$	$I_{PP} = 4.0A, t_p = 8/20\mu s$		10	15	V
Junction Capacitance	$C_j$	$V_R = 0V, f = 1MHz$ I/O to I/O		0.3	0.35	pF
		$V_R = 0V, f = 1MHz$ I/O to GND		0.6	0.7	pF

### Electrical Parameters (TA = 25°C unless otherwise noted)

Symbol	Parameter
$I_{PP}$	Maximum Reverse Peak Pulse Current
$V_C$	Clamping Voltage @ $I_{PP}$
$V_{RWM}$	Working Peak Reverse Voltage
$I_R$	Maximum Reverse Leakage Current @ $V_{RWM}$
$V_{BR}$	Breakdown Voltage @ $I_T$
$I_T$	Test Current

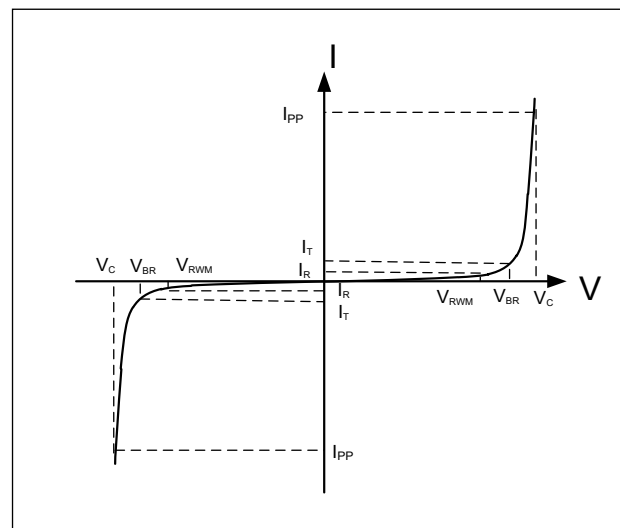

Note: 8/20 $\mu s$  pulse waveform.

## Typical Characteristics

Fig.1 Peak Pulse Power Rating Curve

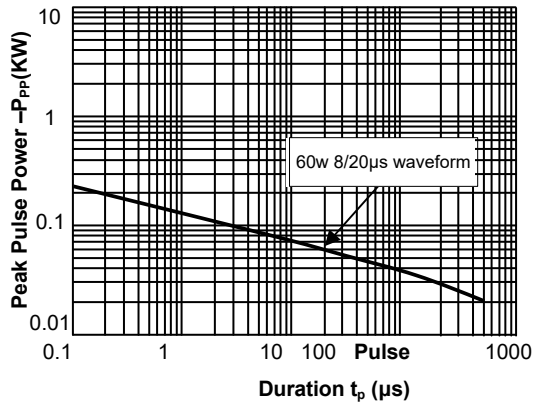

Fig.2 Pulse Derating Curve

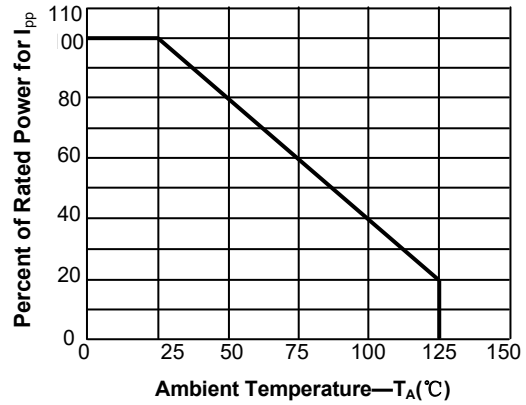

Fig.3 Pulse Waveform-8/20μs

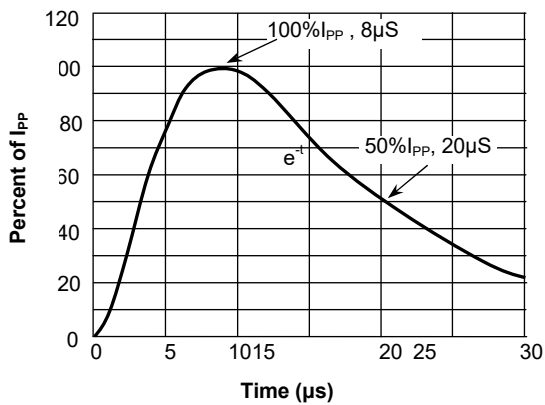

Fig.4 Pulse Waveform-ESD(IEC61000-4-2)

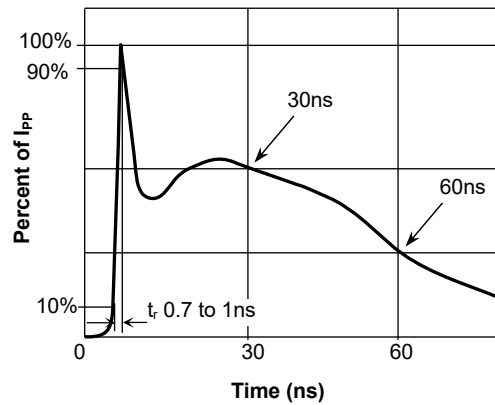

Fig.5 Eye Diagram - HDMI mask at 5.0Gbps per channel

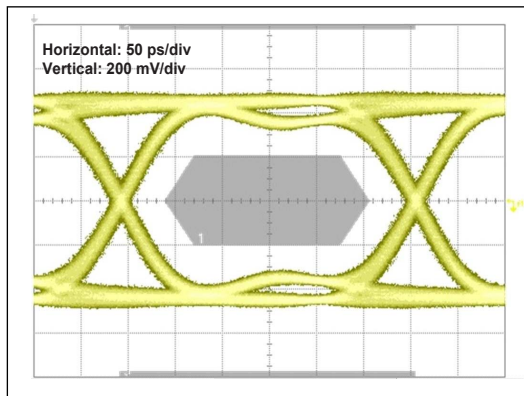
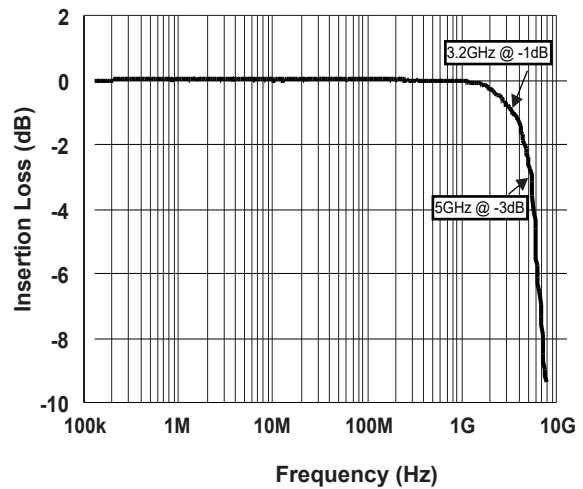
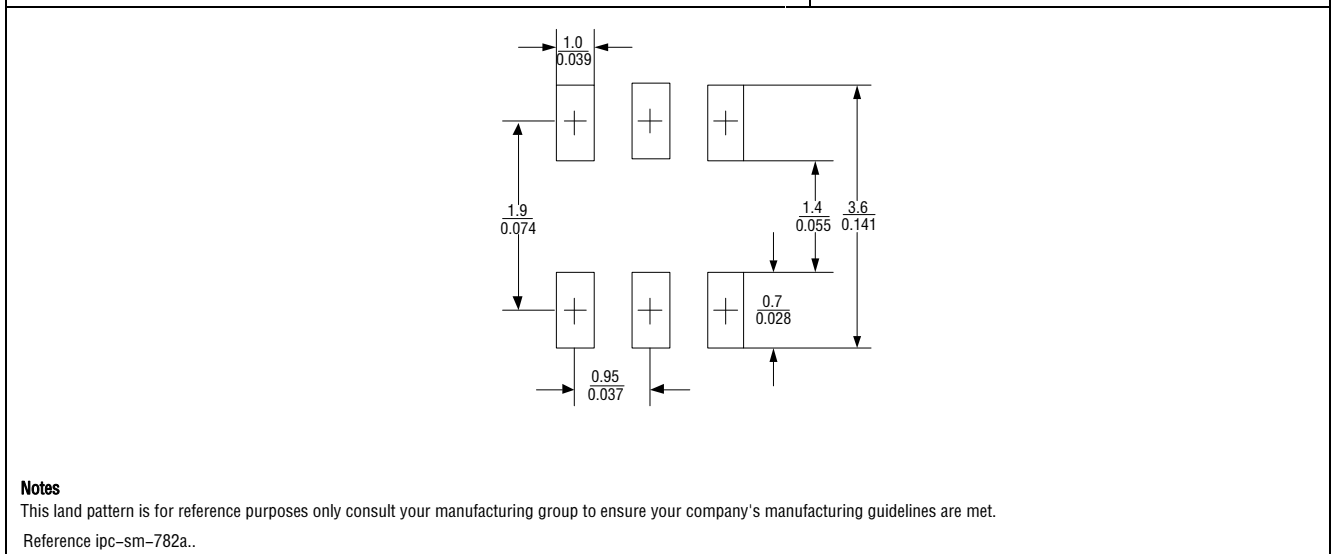
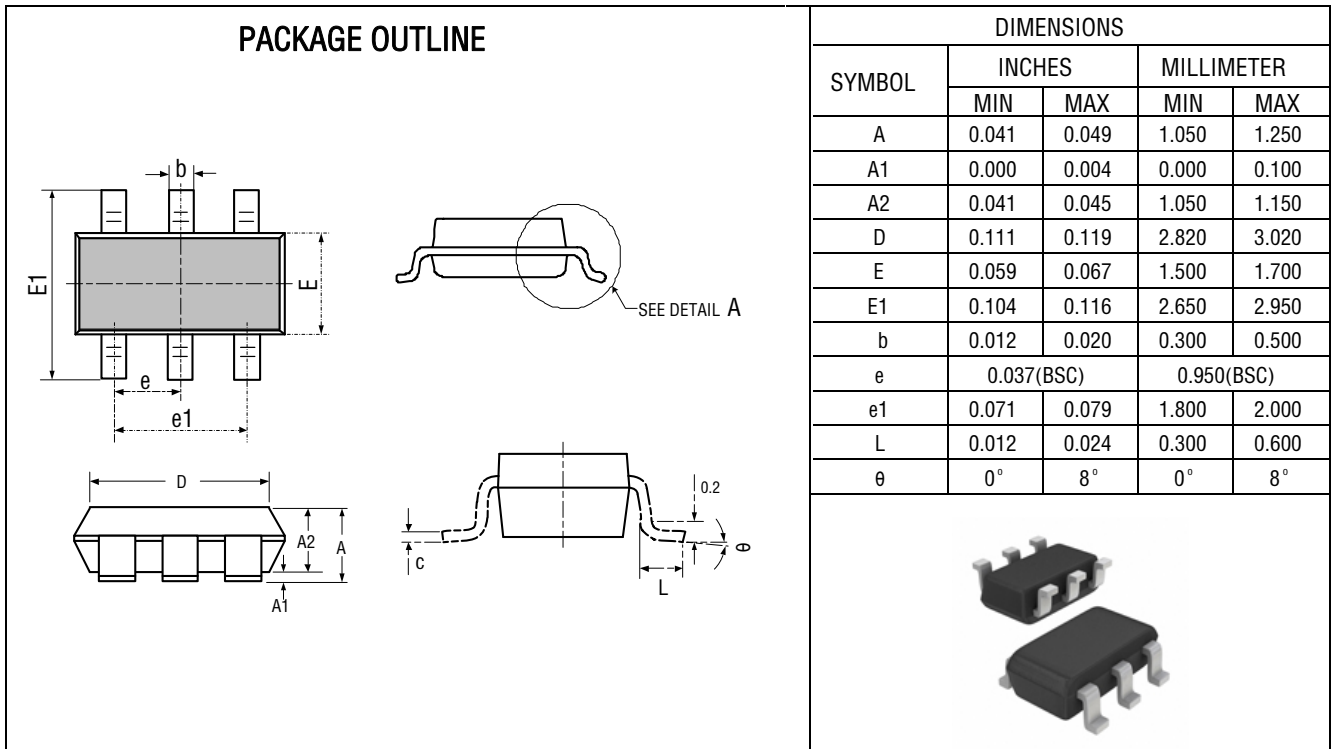

Fig.6 Insertion Loss S21 - I/O to GND



Ultra-Low Capacitance Series  
ESD Protection  
**PTT236U03M5CA6**

### Outline Drawing



### Marking

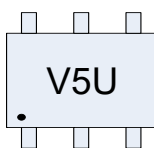

### Ordering information

Order code	Package	Base qty	Delivery mode
PTT236U03M5CA6	SOT23-6	3k	Tape and reel