

## Features

- Ultra small package: 1.6x1.0x0.5mm
- Protects one data or power line
- Working voltage: 4.5V
- 2-pin leadless package
- RoHS Compliant

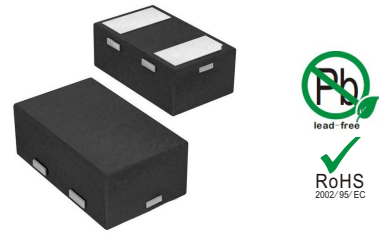

**DFN1610**

## IEC COMPATIBILITY (EN61000-4)

- IEC 61000-4-2  $\pm 30\text{kV}$  contact  $\pm 30\text{kV}$  air
- IEC 61000-4-5 (Lightning) 135A (8/20 $\mu\text{s}$ )

## Applications

- Mobile Phones
- Battery Protection
- Power Line Protection
- Vbat pin for Mobile Devices
- Hand Held Portable Applications

## Mechanical Characteristics

- Package: DFN1610-2 (1.6x1.0x0.5mm)
- Case Material: "Green" Molding Compound.
- UL Flammability Classification Rating 94V-0
- Moisture Sensitivity: Level 3 per J-STD-020
- Terminal Connections: See Diagram Below

## Schematic & PIN Configuration

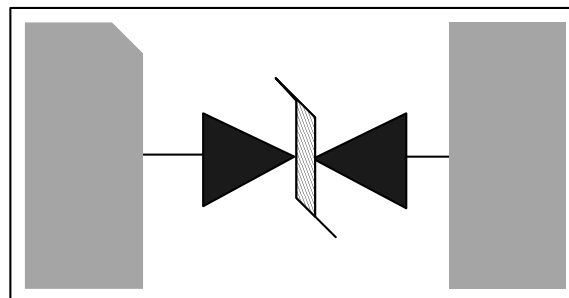

**DFN1610**

**Absolute Maximum Rating** (TA=25°C, RH=45%-75%, unless otherwise noted)

Parameter	Symbol	Value	Unit
Peak Pulse Power (tp=8/20µs waveform)	P <sub>pp</sub>	2500	W
Peak Pulse Current (8/20µs)	I <sub>pp</sub>	180	A
ESD per IEC 61000-4-2 (Air)	V <sub>ESD</sub>	±30	kV
ESD per IEC 61000-4-2 (Contact)		±30	
Operating Temperature Range	T <sub>J</sub>	-55 to +125	°C
Storage Temperature Range	T <sub>stg</sub>	-55 to +150	°C

**Electrical Characteristics**(TA=25°C)

Parameter	Test Condition	Symbol	Min	Typ	Max	Unit
Reverse Working Voltage		V <sub>RWM</sub>			4.5	V
Breakdown Voltage	I <sub>T</sub> = 1mA	V <sub>BR</sub>	4.8			V
Reverse Leakage Current	V <sub>RWM</sub> = 4.5V	I <sub>R</sub>			0.2	uA
Clamping Voltage	I <sub>PP</sub> = 20A (8 x 20µs pulse)	V <sub>C</sub>			7	V
Clamping Voltage	I <sub>PP</sub> = 180A (8 x 20µs pulse)	V <sub>C</sub>			13.8	V
Junction Capacitance	V <sub>R</sub> = 0V, f = 1MHz	C <sub>J</sub>		250		pF

**Electrical Parameters** (TA = 25°C unless otherwise noted)

Symbol	Parameter
I <sub>PP</sub>	Maximum Reverse Peak Pulse Current
V <sub>C</sub>	Clamping Voltage @ I <sub>PP</sub>
V <sub>RWM</sub>	Working Peak Reverse Voltage
I <sub>R</sub>	Maximum Reverse Leakage Current @ V <sub>RWM</sub>
V <sub>BR</sub>	Breakdown Voltage @ I <sub>T</sub>
I <sub>T</sub>	Test Current

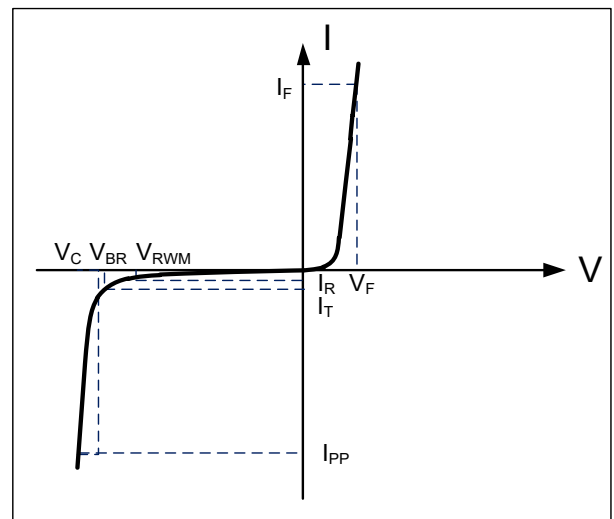

Note: 8/20µs pulse waveform.

**Typical Performance Characteristics**(TA=25°C unless otherwise Specified)

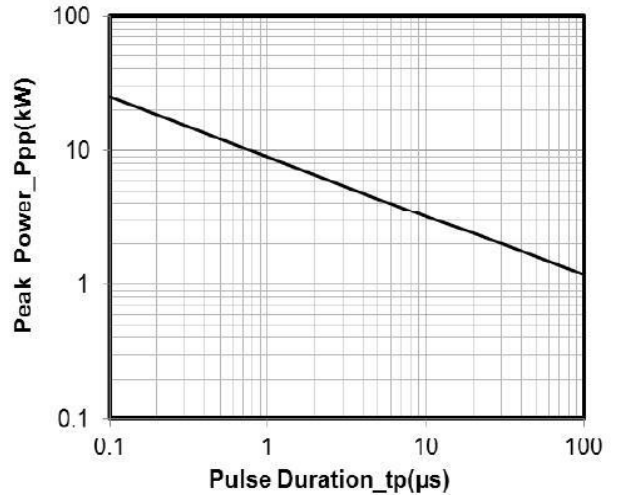

**Peak Pulse Power vs. Pulse Time**

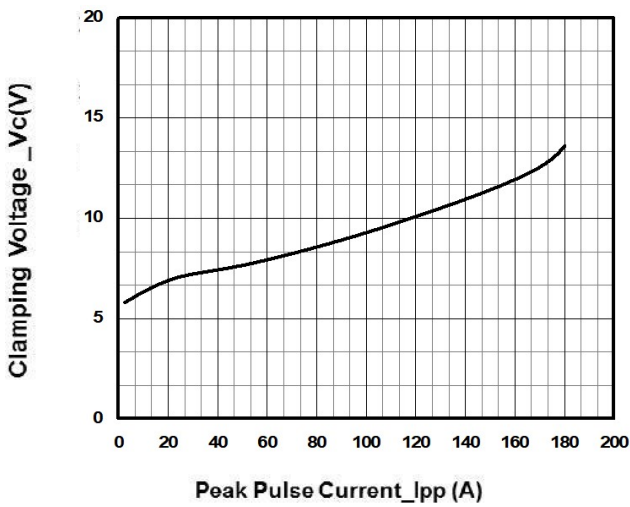

**Clamping Voltage vs. Peak Pulse Current**

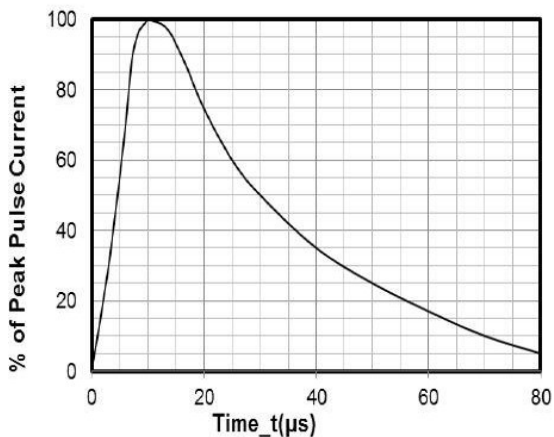
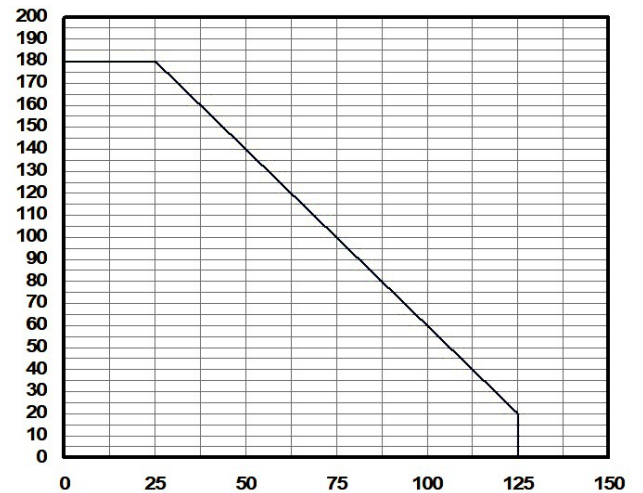

**8 X 20μs Pulse Waveform**

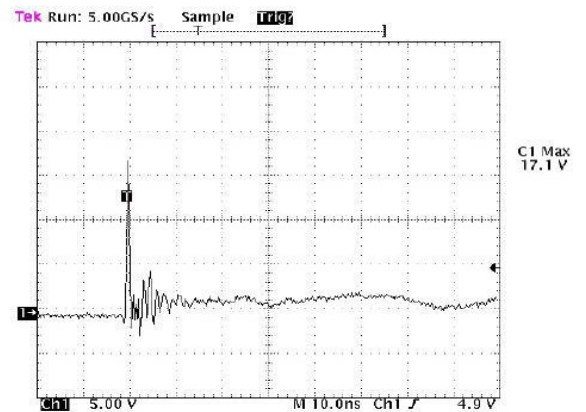

**Note: Data is taken with a 10x attenuator**  
**ESD Clamping Voltage**  
**+8 kV Contact per IEC61000-4-2**

## Package Mechanical Data

SYM	DIMENSIONS					
	MILLIMETERS			INCHES		
	MIN	NOM	MAX	MIN	NOM	MAX
A	0.45	0.50	0.55	0.018	0.020	0.022
A1	0.00	0.02	0.05	0.000	0.001	0.002
b	0.75	0.80	0.85	0.030	0.032	0.034
c	0.10	0.15	0.20	0.004	0.006	0.007
D	1.55	1.60	1.65	0.062	0.064	0.066
e	1.10 BSC			0.044 BSC		
E	0.95	1.00	1.05	0.038	0.040	0.042
L	0.35	0.40	0.45	0.014	0.016	0.018
h	0.15	0.20	0.25	0.006	0.008	0.010

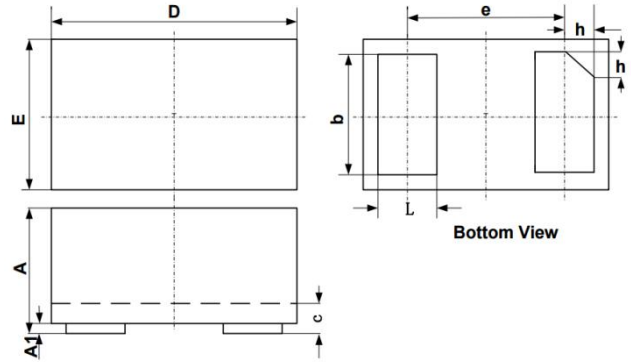

## Suggested Land Pattern

SYM	DIMENSIONS	
	MILLIMETERS	INCHES
X	1.00	0.040
Y1	0.62	0.025
Y2	0.60	0.024
Y3	1.22	0.049
Z	1.85	0.074

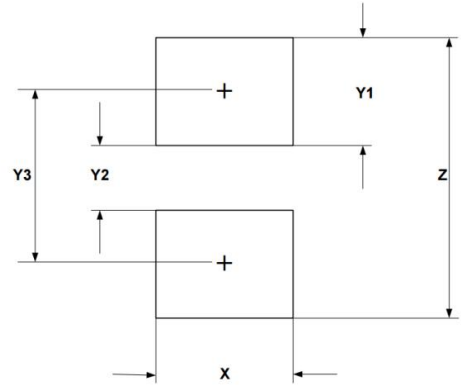

## Ordering information

Order code	Package	Base qty	Delivery mode
PTN162H250S4B250	DFN1610	3k	Tape and reel