

Description

The PG5D7 Series surge arresters are specifically designed for protection of electrical and communication equipment against over voltage transients in surface mount assembly applications. This series offers the most cutting edge protection using non-radioactive elements.



(5x7.6mm)
PG5D7T Series



(5x7.6mm)
PG5D7Y Series

Features

- Excellent stability on multiple pulse duty cycle
- Excellent response to fast rising transients.
- Ultra Low Insertion Loss
- 5KA surge capability tested with 8/20 μ S
Non-Radioactive
- Low capacitance (≤ 1 pF)
- Voltage Ranges 90V to 600V
- RoHS compliant and Lead-free



Applications

- Communication equipment
- CATV equipment
- Test equipment
- Data lines
- Power supplies
- Telecom SLIC protection
- Broadband equipment
- ADSL equipment, including ADSL2+
- XDSL equipment
- Satellite and CATV equipment
- General telecom equipment

Electrical Characteristics

Part No.	DC Breakdown in Volts (@100V/s)	Impulse Breakdown in Volts (@1kV/ μ s) Max.(V)	Insulation Resistance		Capacitance (@1KHz) Max.	Nominal Impulse Discharge Current (@8/20 μ s)	Nominal Discharge Current (1sec/50Hz)
			Min.	DC			
PG5D7xN090A	90 \pm 25%	700	1G Ω	50V	≤ 1.0 pf	5.0 kA	5.0 A
PG5D7xN150A	150 \pm 25%	750		50V	≤ 1.0 pf		
PG5D7xN230A	230 \pm 20%	800		100V	≤ 1.0 pf		
PG5D7xN350A	350 \pm 20%	850		100V	≤ 1.0 pf		
PG5D7xN470A	470 \pm 20%	1050		100V	≤ 1.0 pf		
PG5D7xN600A	600 \pm 20%	1200		100V	≤ 1.0 pf		

*Devices test at ambient temperature of 25°C, Operation temperature -40~125°C
"x"Code letter for product packages

Soldering Parameters - Reflow Soldering

Reflow Condition		Pb – Free assembly
Pre Heat	- Temperature Min ($T_{s(min)}$)	150°C
	- Temperature Max ($T_{s(max)}$)	200°C
	- Time (Min to Max) (t_s)	60 – 180 secs
Average ramp up rate (Liquidus Temp (T_L) to peak)		3°C/second max
$T_{s(max)}$ to T_L - Ramp-up Rate		5°C/second max
Reflow	- Temperature (T_L) (Liquidus)	217°C
	- Temperature (t_l)	60 – 150 seconds
Peak Temperature (T_p)		260 ^{+0/-5} °C
Time within 5°C of actual peak Temperature (t_p)		8 – 20 seconds
Ramp-down Rate		6°C/second max
Time 25°C to peak Temperature (T_p)		8 minutes Max.
Do not exceed		260°C

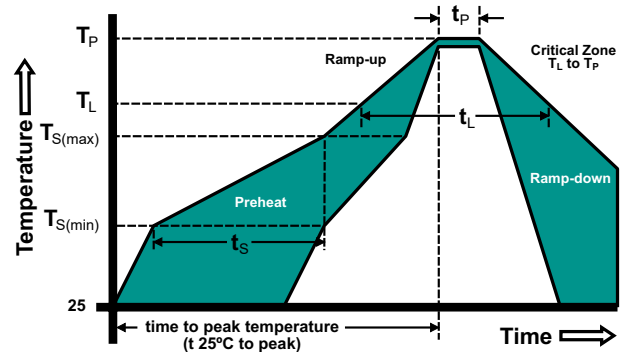

Soldering Parameters - Hand Soldering

Solder Iron Temperature: 350° C +/- 5° C
 Heating Time: 5 seconds max.

Product Characteristics

Materials	Element: Silver or Silver Ceramic Body / End plate Metallization of ceramic body High temperature solder preform End termination overcoat: Nickel Flash, Tin/Lead
Storage and Operational Temperature	-40 to +90 °C

Voltage vs. Time Characteristic

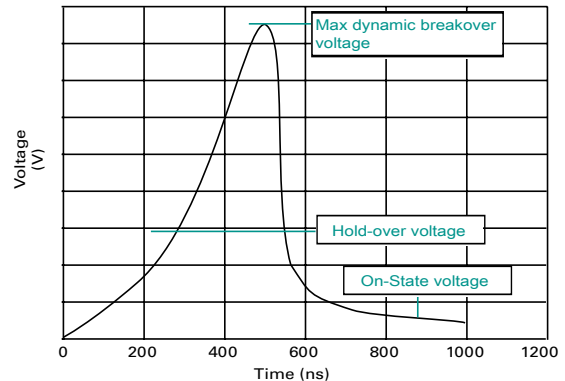

Soldering Parameters - Wave Soldering (Thru-Hole Devices)

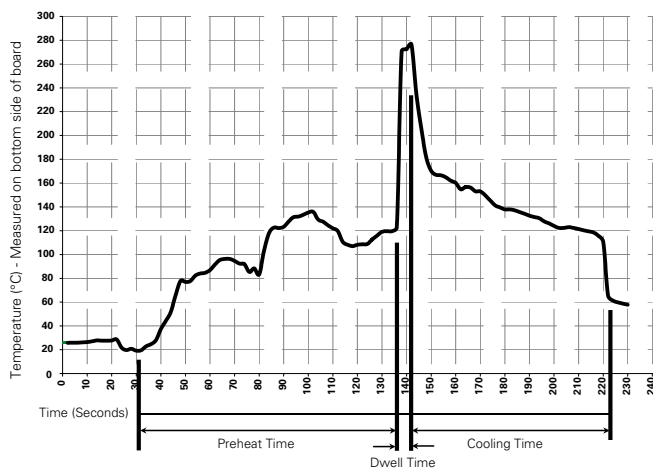

Recommended Process Parameters:

Wave Parameter	Lead-Free Recommendation
Preheat: (Depends on Flux Activation Temperature)	(Typical Industry Recommendation)
Temperature Minimum:	100° C
Temperature Maximum:	150° C
Preheat Time:	60-180 seconds
Solder Pot Temperature:	280° C Maximum
Solder Dwell Time:	2-5 seconds

Note: These devices are not recommended for IR or Convection Reflow process.

Device Dimensions (Unit/mm)

PG5D7T Seires

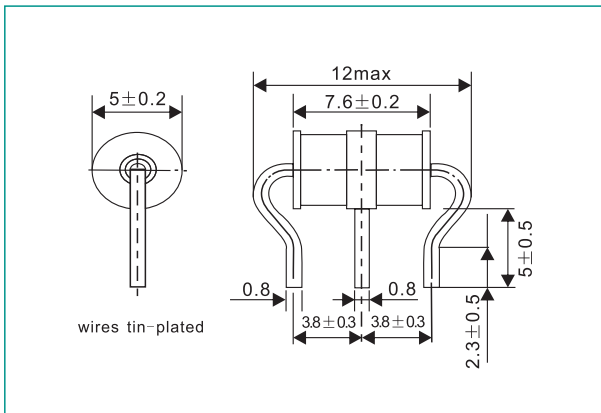

PG5D7Y Seires

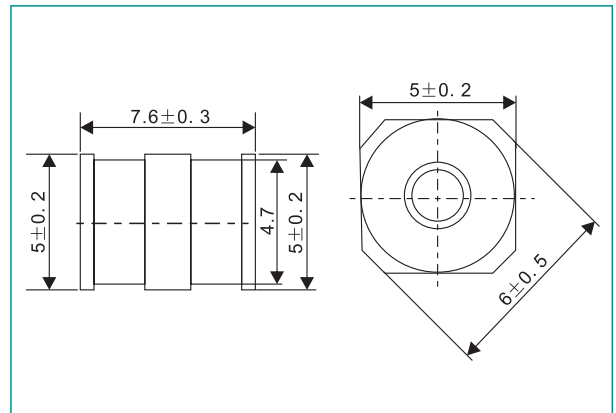

Packaging (Tape and Reel)

Part Number	Description	Quantity
PG5D7Y	1000PCS Per Reel,8000PCS in box,24000PCS outer box	24000pcs
PG5D7T	100PCS Per Reel,500PCS in box,5000PCS outer box	5000pcs