

Volts-1000VDC Amps-40 to 50A Electric Vehicle Auxiliary Fuses

14CT10 Series

The Prosemi EV (Electric Vehicle) fuses are made of high strength ceramic tube and high purity melt, with unique arc extinction filling technology which is Prosemi's patent technology. The EV fuses are elaborately designed according to the actual driving status of EVs, with adherence to auto industry standards (JASO, D622/ISO8820). With high vibration durability, perfect transient current intermittent tolerance, eminent thermal shock resistance and favorable flame retardant ability, the Prosemi fuses will provide you protection whether the vehicle is traveling on a flat road or under a variety of harsh conditions.



Features

- DC fuse for EV/HEV/ESS
- Stud-mount, optional for other installation
- Excellent DC performance
- Design to EV fuse standard UL248-20
- Reliability performance design refer to ISO8820-8&GB/T31465.6
- Comply RoHS directive

Operating time rating

% of Ampere Rating (A)	Operating Time (S)	
	Min	Max
2.0In	0.5	100
3.0In	0.1	15
5.0In	0.05	1

Specification

Part Number	Rated Current (A)	Rated Voltage/ Interrupting rating	I^2t (A ² S) Melting Pre-arc	Power Loss @ 0.5In 0.5In (W)
14CT10-40A-Y	40	1000Vdc/50000A	1440	1.3
14CT10-50A-Y	50		4000	1.45

Note: I^2t is measured with 10In

Part Numbering System

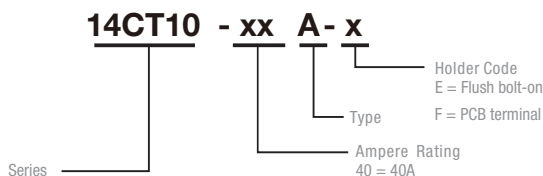

Volts-1000VDC Amps-40 to 50A
Electric Vehicle Auxiliary Fuses

14CT10 Series

Dimension Unit: mm

14CT10-xxA-E

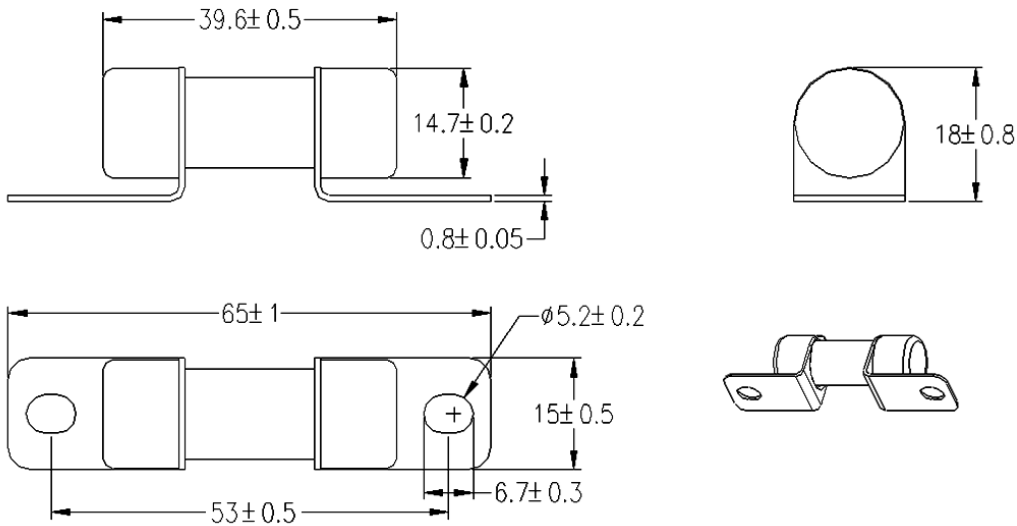

Note: recommend tightening torque is 4.5+/-1.0Nm.

14CT10-xxA-F

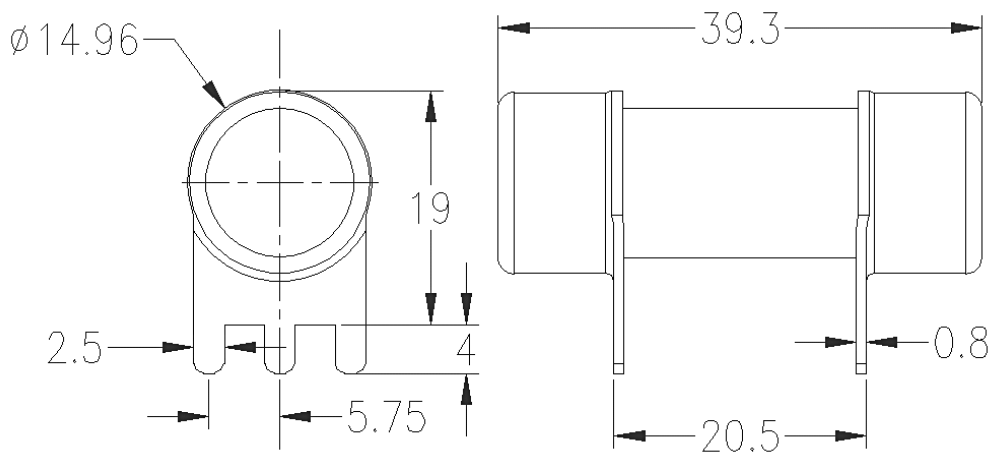

Recommended Drilling Pattern

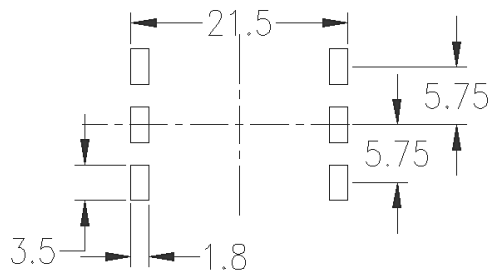

Volts-1000VDC Amps-40 to 50A

Electric Vehicle Auxiliary Fuses

14CT10 Series

Average Time Current Curves

40A-50A

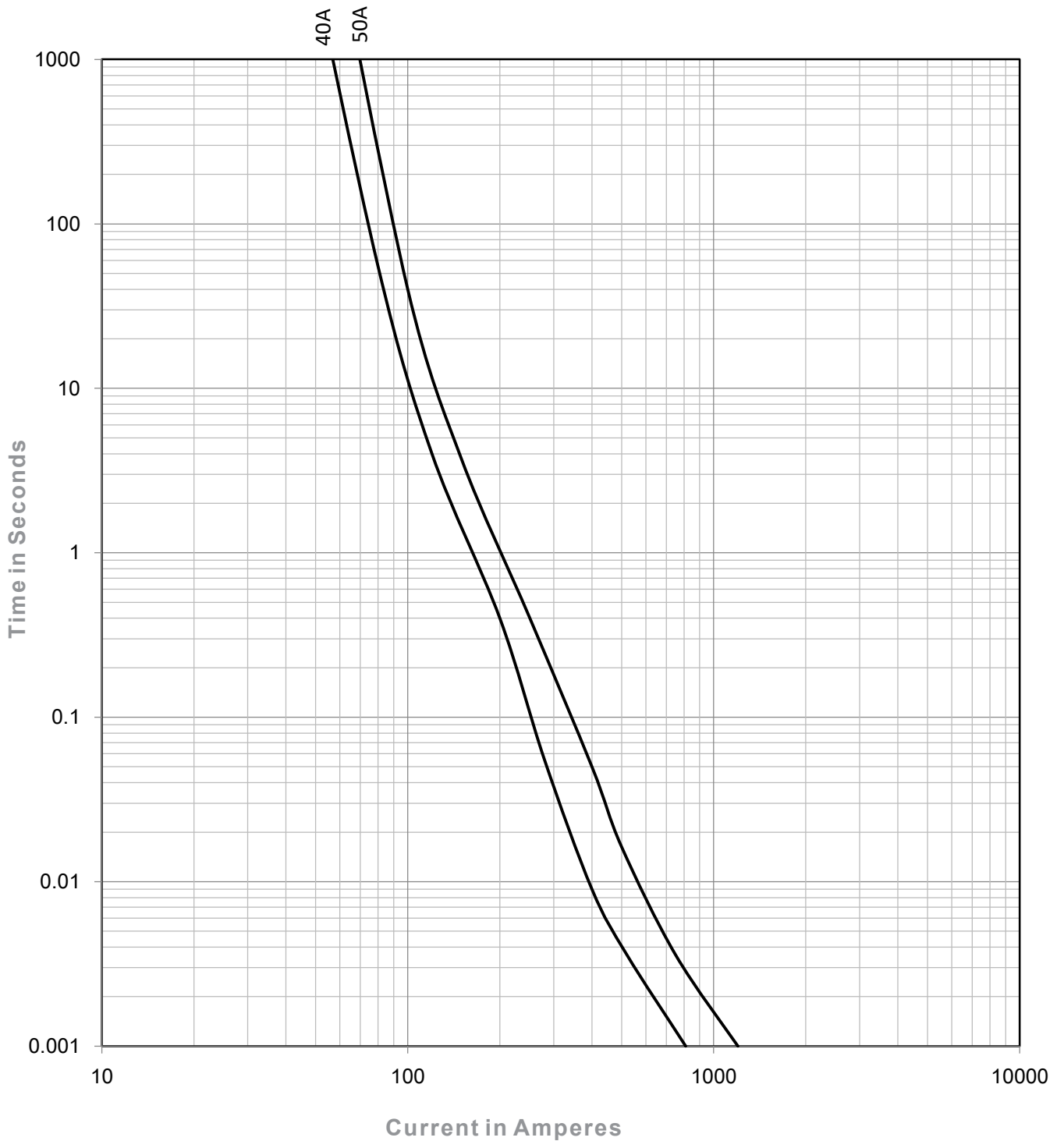

Volts-1000VDC Amps-40 to 50A

Electric Vehicle Auxiliary Fuses

14CT10 Series

Transportation and Storage

During transportation and storage, should avoid water seepage and mechanical damage.

Conditions for operation in service

Where the following conditions apply, fuses complying with this standard are deemed capable of operating satisfactorily without further qualification.

If the operating conditions exceed the following requirements, please contact manufacturer.

- Normal temperature: -5°C to 40°C;
- The altitude of the site of installation of the fuses does not exceed 2 000 m above sea level;
- The air is clean and its relative humidity does not exceed 50% at the maximum temperature of 40°C;
- Higher relative humidities are permitted at lower temperatures, e.g. 90 % at 20°C;
- Under these conditions, moderate condensation may occasionally occur due to variation in temperature.

Vibration

Meet UL248-20 Section 8.6.2.3 Vibration Test C requirement, can be use on Electrical Vehicle application;

Temperature Derating Curve

Operating Temperature: -40°C to +125°C, with proper rerating factor applied.

